



[logicdesign.ld@gmail.com](mailto:logicdesign.ld@gmail.com)

**One Point Solution from Design to Manufacturing.**

**GST No : 33JNJPS9997D1Z1**

# ABOUT US

Logic Design Solution is a startup founded by G Sundharesh with expertise in supply chain packaging design and custom machinery. We specialize in creating innovative solutions that optimize packaging, improve efficiency, and design specialized machines tailored to your business needs. Our mission is to provide smarter, cost-effective solutions that drive operational success.



# OUR ROADMAP

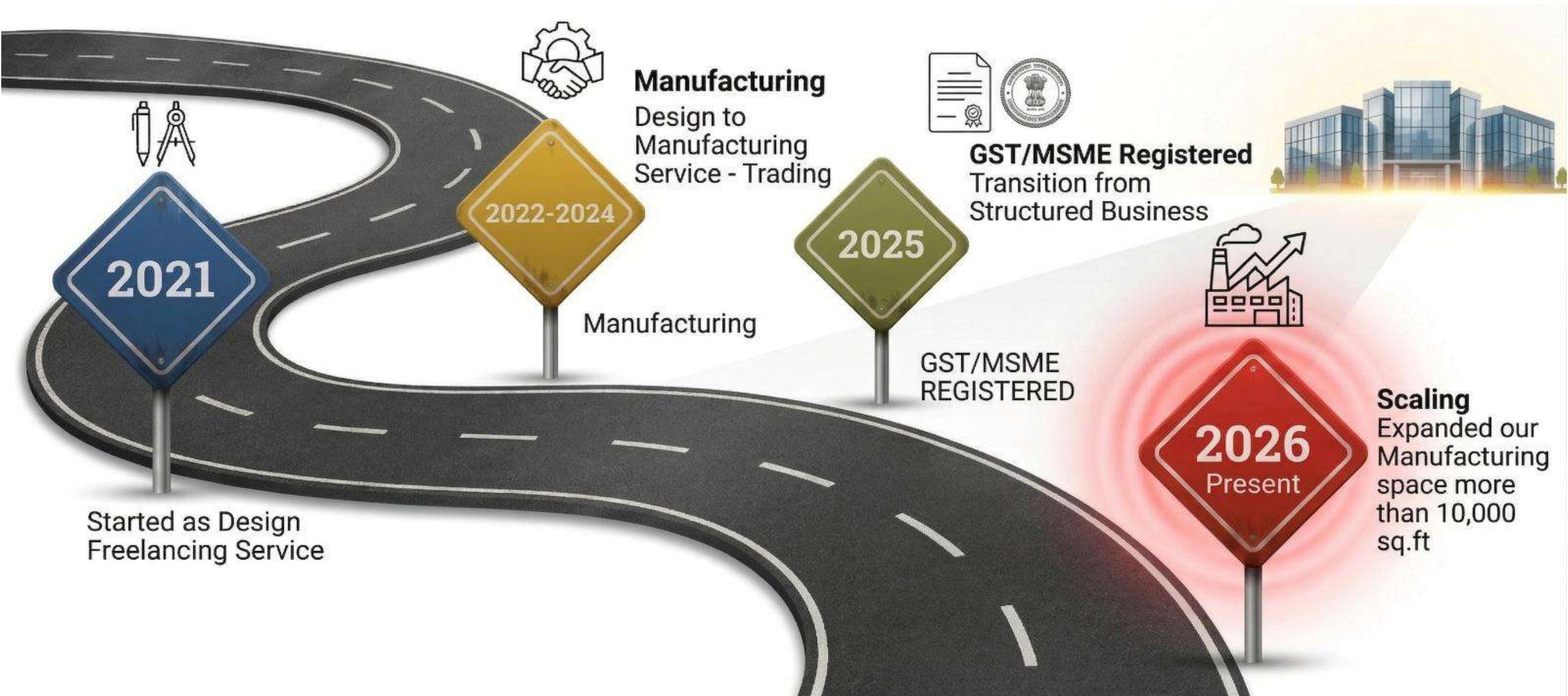



To empower brands through innovative design solutions that inspire, engage, and connect with audiences. We believe in the power of creativity to transform ideas into meaningful experiences, making design both functional and beautiful.



To be a leading force in shaping the future of design by fostering innovation, sustainability, and collaboration. We aim to create designs that not only drive business success but also make a lasting impact on culture and the environment.

# OUR SERVICES



Packaging Service



Design Service



Special Purpose Machine

# PACKAGING SERVICE

# PLASTIC SOLUTIONS



Veg - Rigid Crate



Automobile - Rigid  
Crate



Foldable Crate

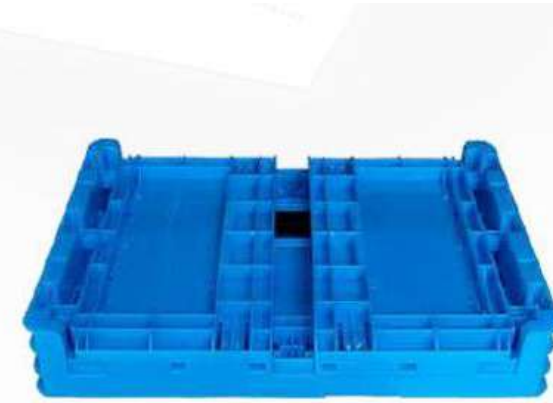

Rigid Crate with Poly Cover



Rigid Crate with Lid



Pallet Sleeve Box



Foldable Large Container



Pallet Collar

# **PLASTIC SOLUTIONS**



FLC



FSC



PP - Box



PP - Dunnage



PET - Tray



HDPE - Dunnage



VF - Tray



# **METAL SOLUTIONS**



ESR

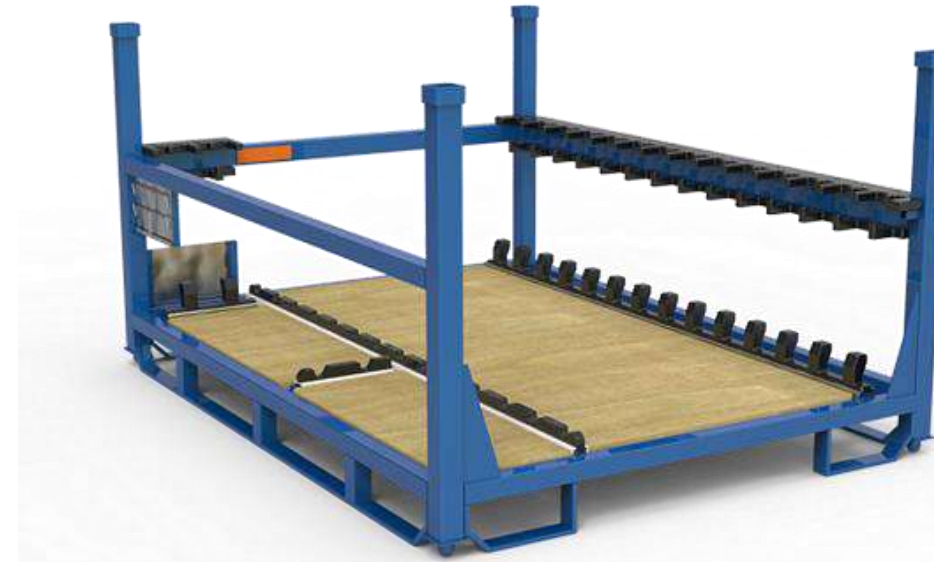

RSR



Foldable Bin

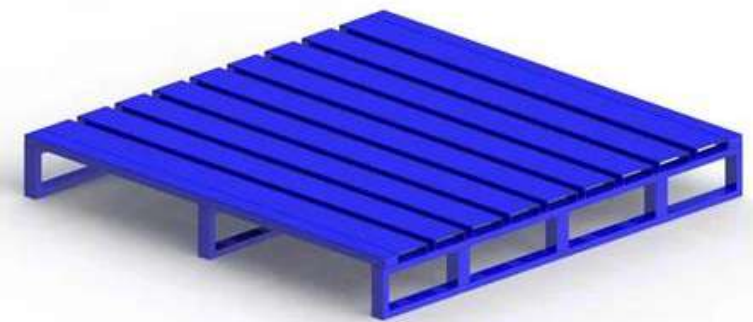

Metal Pallet



Customized Metal Bin



Trolley

# WOOD & CORRUGATED SOLUTIONS



Wooden Box



Wooden Pallet



Wooden Collar



Export Heavy Duty Corrugated Box



Corrugated Box



Wooden Pallet With Metal Sleeve

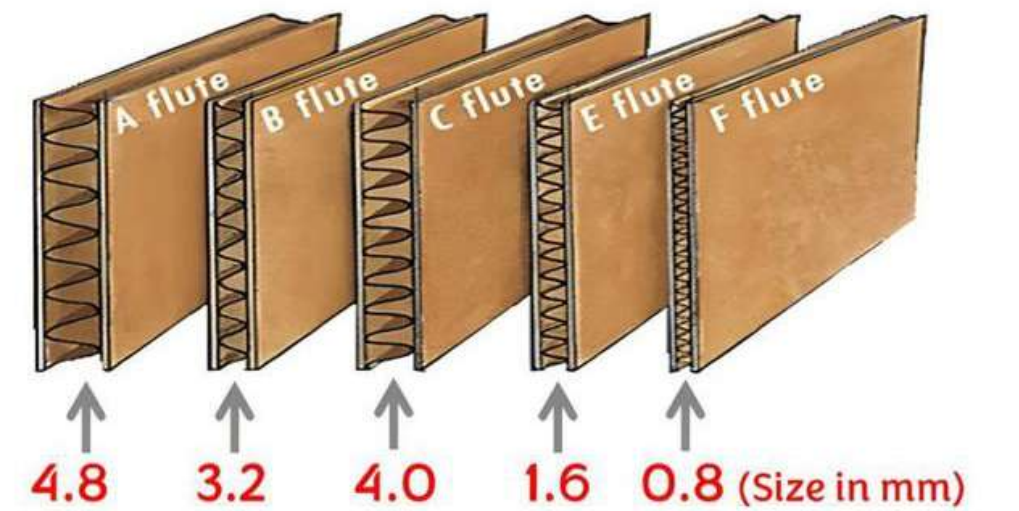

# CONSUMABLES SOLUTIONS



Stretch Film



BOPP Tape



Pet Strap



VCI Cover



XLPE - Foam

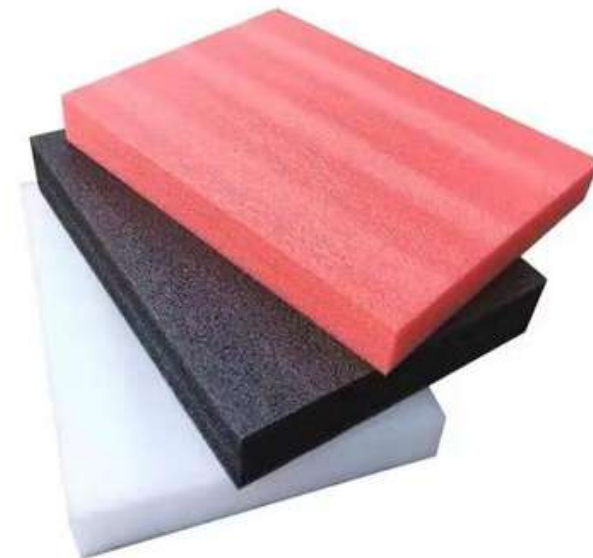

EPE - Foam



PU - Foam



3D VCI - Bag

# CONTAINER VANNING

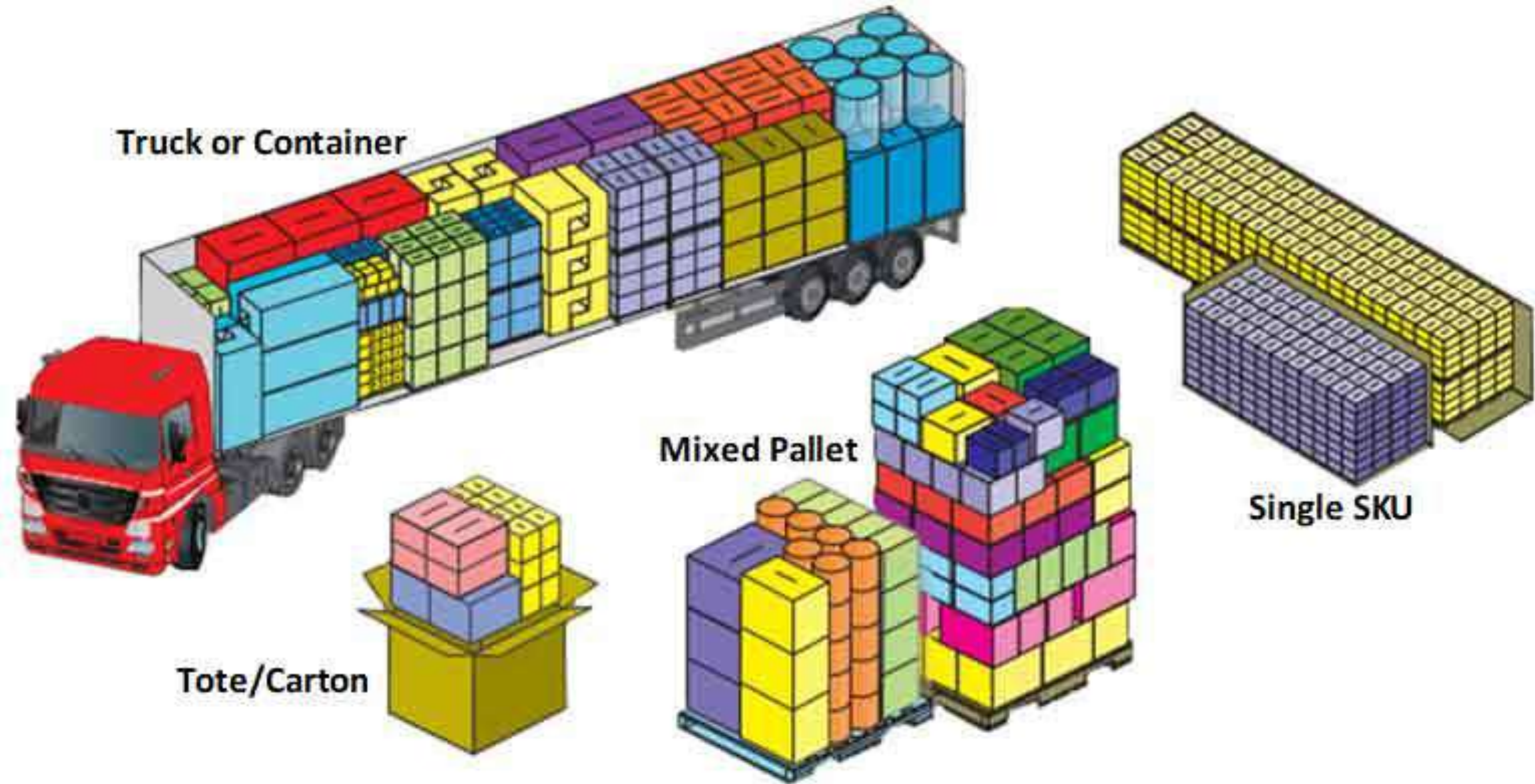

# **MATERIAL HANDLING**



# DESIGN SERVICE

# ***OUR DESIGN SECTORS***

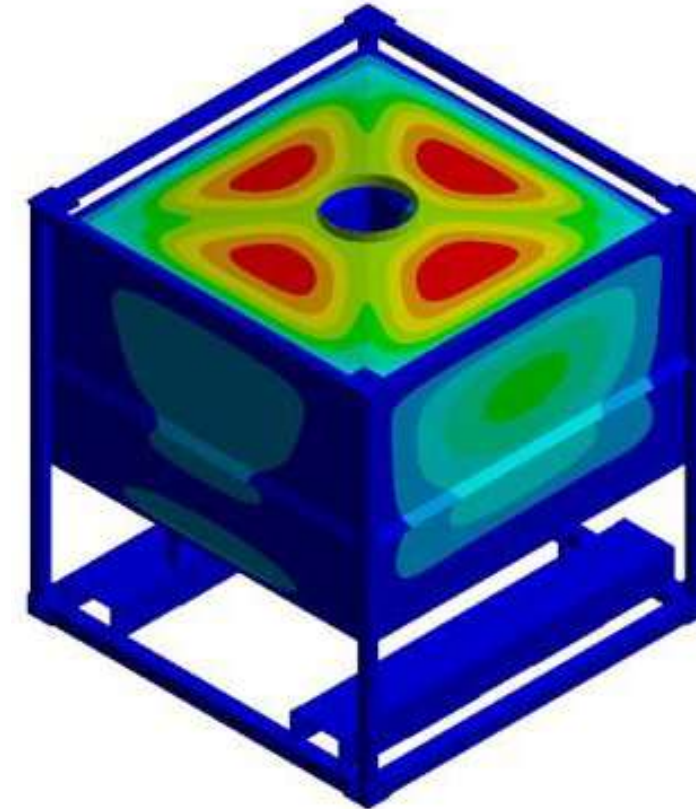
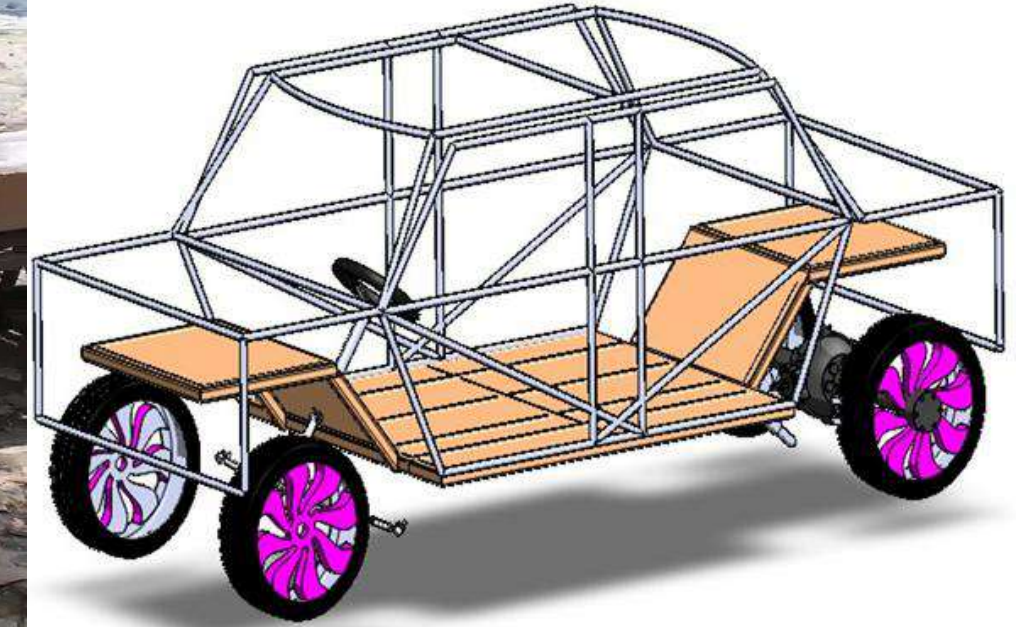
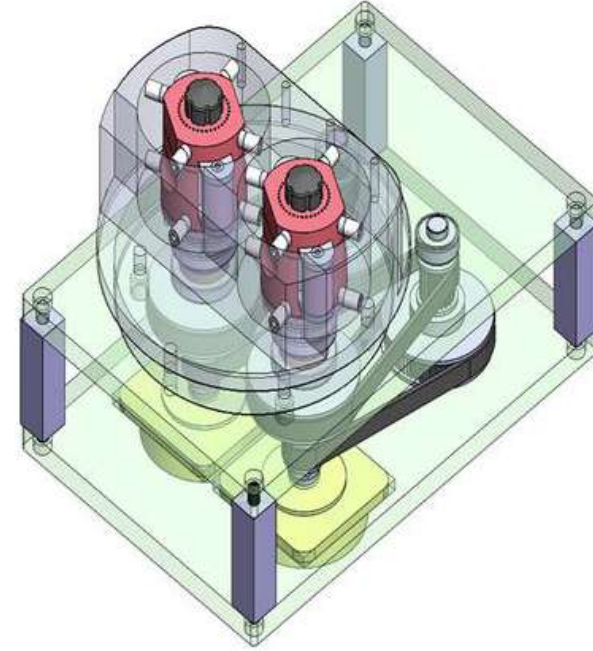

# SPECIAL PUPOSE MACHINE



# Project

## **Bottle Filling Machine**

Our state-of-the-art bottle filling machine is designed to deliver precision, efficiency, and reliability for packaging bottle in various container types. Built with food-grade materials, it ensures hygiene compliance while offering seamless integration into production lines. Key features include automated filling, customizable volume settings, minimal spillage, and easy maintenance, making it ideal for small-scale to large-scale production.

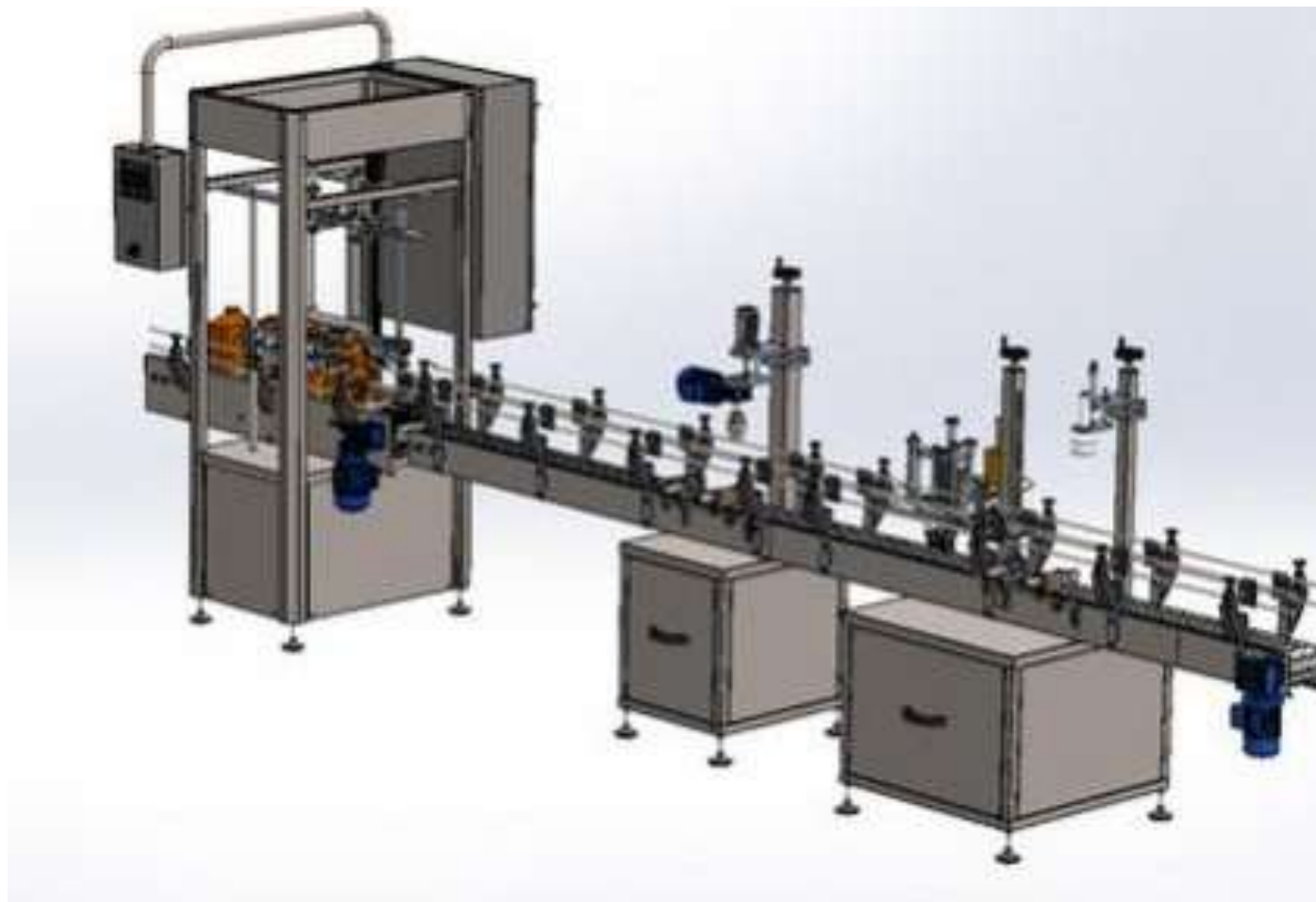

# Project

## **Pouch Packing Machine**

Our pouch packing machine combines advanced technology with robust design to provide efficient and versatile packaging solutions. It is ideal for packing powders, granules, liquids, or semi-solids into pouches of various sizes. Equipped with precision sealing, user-friendly controls, and high-speed operation, the machine ensures consistent performance, minimal wastage, and excellent product integrity. Suitable for diverse industries, it guarantees reliable packaging and easy maintenance.



# Project

## **Capping & Vad Placing Machine**

A capping and vad placing machine automates the process of placing caps and vials onto containers in industries like pharmaceuticals and beverages. The machine ensures precise placement, sealing, and secure closure, improving production speed, consistency, and reducing manual labor. It's essential for high-volume packaging operations.

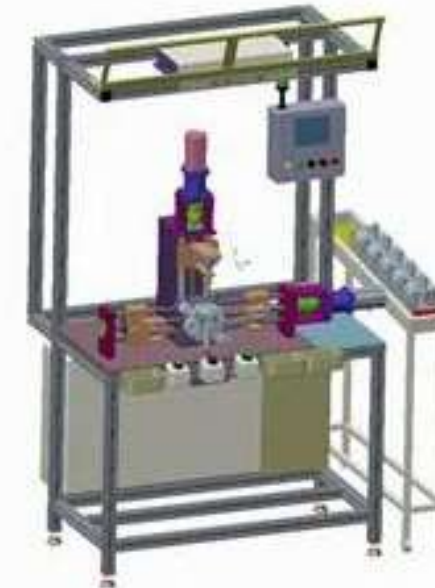
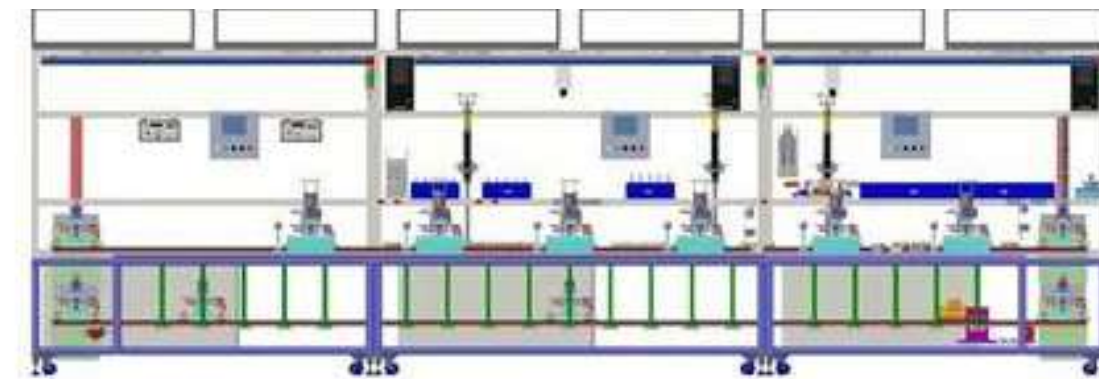
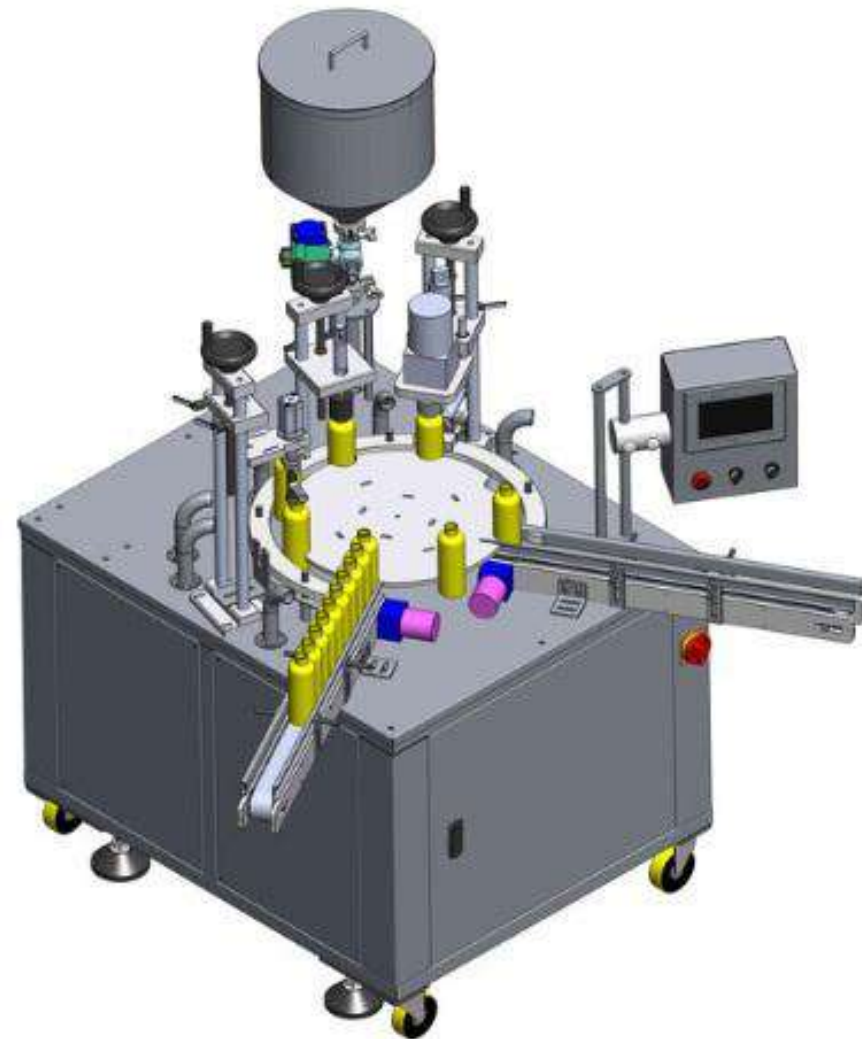

# Project

## **Product-Screw Feeder /Blender machine**

A screw feeder/blender machine is used for conveying and mixing dry materials, powders, or granules in various industries. The screw feeder delivers consistent material flow, while the blender ensures uniform mixing. These machines are essential for processes like food production, pharmaceuticals, and chemicals, improving efficiency and product consistency.

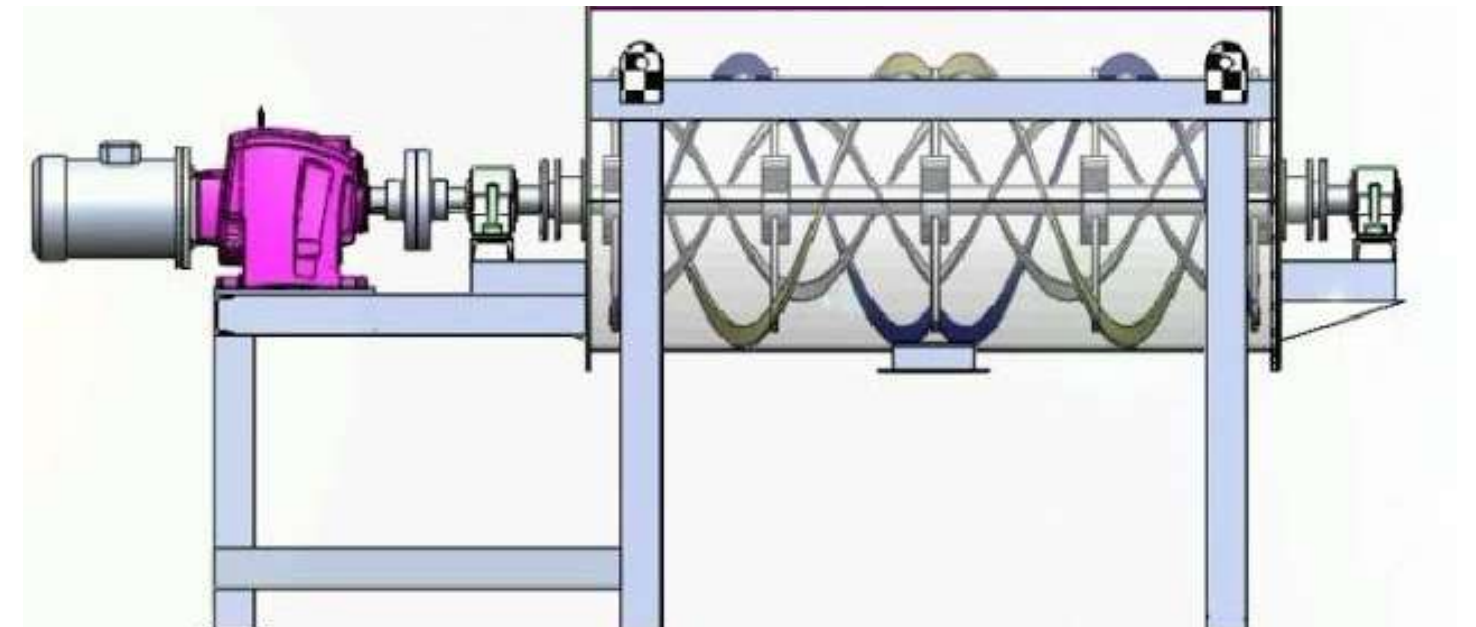

# Project

## **Carton Box Packaging-Roller Conveyor**

A carton box packaging roller conveyor is a system designed to efficiently transport carton boxes during packaging and distribution processes. It uses rollers to move boxes smoothly along a production line, enhancing speed, reducing manual handling, and improving workflow efficiency in industries like logistics, manufacturing, and warehousing.

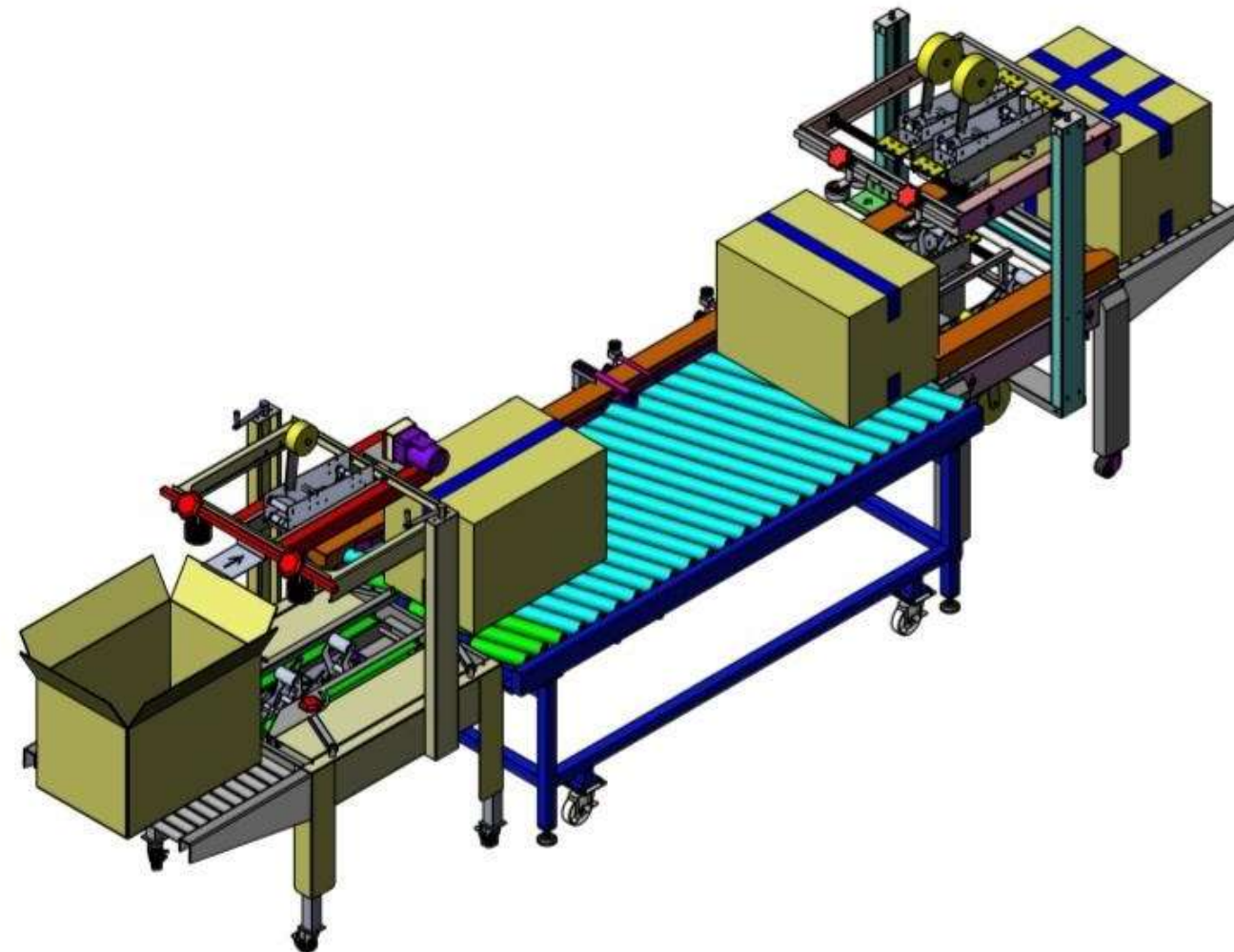

# Contact Us

[Click Here To Explore Us](#)



[www.logicdesign-solutions.com](http://www.logicdesign-solutions.com)



[Logic Design Solutions](#)



[Logic Design](#)



[logicdesign.ld](#)

[Click Here](#)

[logicdesign.ld@gmail.com](mailto:logicdesign.ld@gmail.com)



[+91 - 7639143077](tel:+91-7639143077)





THANK YOU